

the L.W.L. throughout, though a short piece of right angled V at bow and stern will damp some pitching. This hull will manoeuvre easily, have the minimum wetted surface and will weigh less. If it does pitch in light winds, the drag aft will also be less but this is a small consideration compared with the loss of sail drive in pitching.

Sail Development. To date, the Farrar wingsail has clearly shown its superiority to the previous wingsails and, of course, to the sloop. Its only real competitor at the moment is the pocket luff ice yacht rig with a mast bendy enough to untwist the sail. A final improvement might, however, lie in a semi-elliptical sail set, either as a squaresail or "fore-dipping" lugsail. This cannot be known until it is tried.

Centreboards. The boards at present used are the result of aerodynamic theory with few or no tank tests to back the shape up. They are high aspect ratio more or less vertical boards. The evidence from the tank, however, indicates:-

- (1) That the leading edge should be sloped aft at about 65° from the vertical. (Southampton Tests).
- (2) That the aspect ratio should 1:1 (Edmond Bruce).
- (3) The boards should be large (Bruce).

There is no evidence on the shape of the leading edge of the board but it seems reasonable to have this slightly convex with a small concave "fairing" where it joins the hull (Smith: "Why Sailboats Win and Lose Races"). Nor is there much evidence as to whether or no boards should be thin or streamlined shaped.

Conclusion. On the evidence, the boards should be triangles, more or less, being twice as long at the hull as in draught. This at least is a traditional shape as found in the American sailing fishing boats which had no real thickness. Catamarans with the dinghy-type revolving boards could try this shape at little trouble. Those with dagger boards could try it by attaching it to the bottom of their dagger section and putting it into the slot from below.

It is perhaps noteworthy that the shape suggested here is found in the fins of fish.

UNICORN

by Courtesy of the Editor, "Yachts and Yachting"

L.o.a. 18 ft. 0 in.; *beam* 7 ft. 6 in.; *Weight* 120 lbs.

Three years ago, cat designer John Mazzotti came up with a new method of hull construction. By using developed ply panels for either side of the hull and holding them together at the keel at a pre-

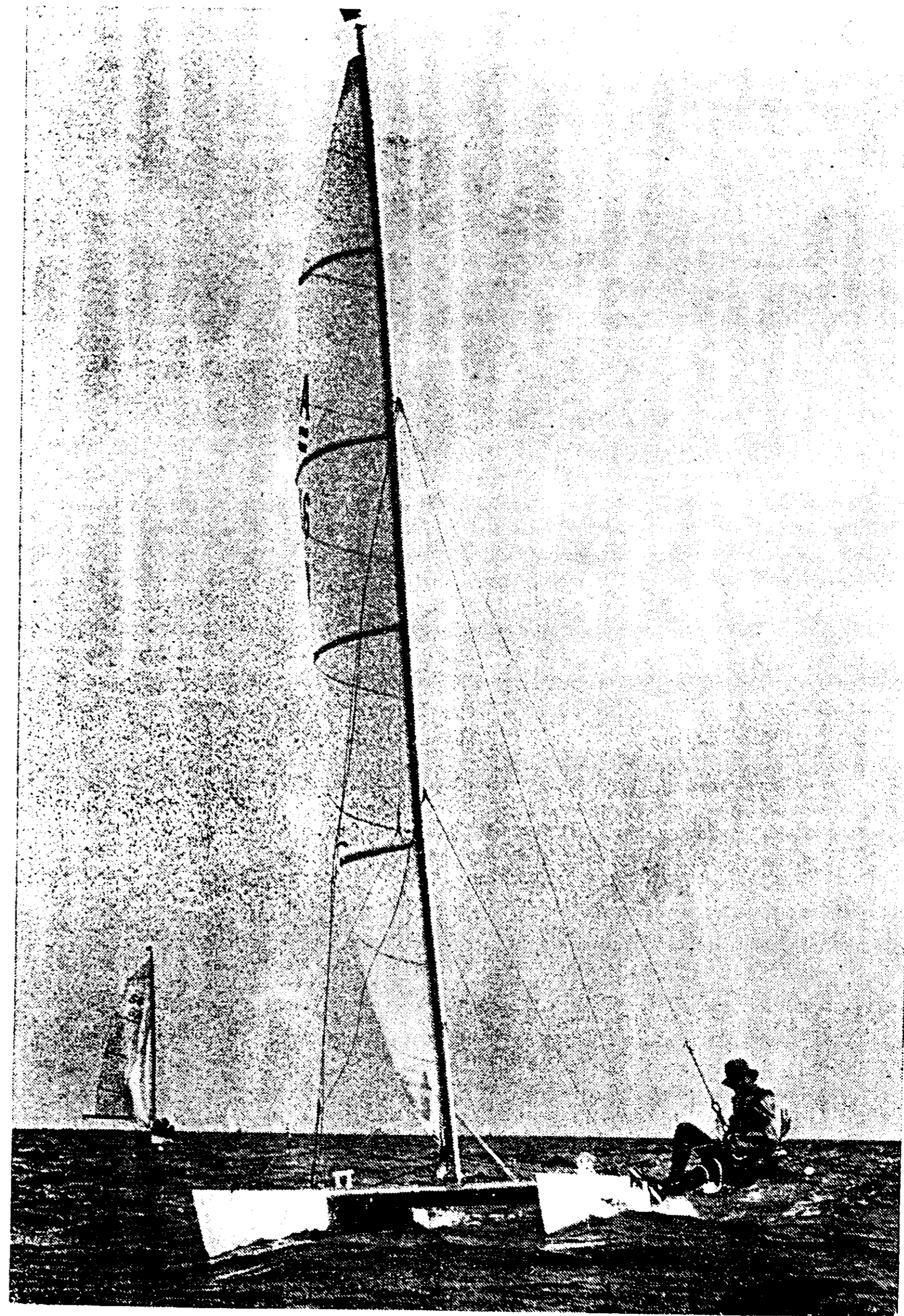

*John Mazzotti uses a trapeze to drive UNICORN on a close reach.
A sliding seat may be fitted if preferred.*

determined angle with fibreglass tape, he found that he was able to fold the panels in towards each other to form a very good shape for a catamaran hull. Early experiments provided the ground-work for Mazzotti's successful "B" Class Manta design.

John Mazzotti has been folding plywood again and his latest design is the very easy to build and extremely quick *UNICORN* "A" Class cat. Once again the designer has produced a boat which is ideal for amateur construction. The building procedure is simplicity itself and no jig is required to produce the right hull shape.

UNICORN is 18 ft. overall and 7 ft. 6 in. maximum beam. These are the maximum length and beam dimensions allowed by the "A" Class rules. The boat carries 150 sq. ft. of sail in a simple una rig and this, coupled with the extremely low all-up weight of about 150 lb. ensures a very high turn of speed.

The "A" Class singlehanders are allowed to use either a trapeze or a sliding seat as a sitting out aid and *UNICORN* can be fitted with either. The designer himself prefers to use the trapeze because it is so simple and because a sliding seat increases the all-up weight by 10 pounds or so.

At first glance, an "A" Class cat might seem to be something of a problem to manhandle ashore. However, not only is *UNICORN* extremely light but she can be knocked down into her main components of hulls, cross beams and spars very quickly indeed once she has been brought ashore. Trailing is no problem and the boat is as easy and quick to assemble as it is to take to pieces.

The original method of stressed skin hull construction makes for great strength because localised stresses cannot build up but are dissipated throughout the skin. Only two bulkheads are used in the construction and these are glass taped into the hulls after they have been folded to shape. One is positioned just ahead of the main beam which is made from a length of standard mast section tubing and carries the mast. The other is fitted in way of the after beam which carries the mainsheet track.

Limber holes are provided in each bulkhead at the keel line so that any water finding its way into either hull is easily run out through the drain hole in the transom. No reserve foam buoyancy is needed because, in the event of a hull being holed below the waterline, sufficient water will flow into the hull to flood the compartments between the bulkheads above the level of the limber holes. Water will continue to flow into the damaged hull only against increasing air pressure and a balance will be reached while the hull still has plenty of buoyancy.



UNICORN's una rig carries a typical catamaran sheeting arrangement. A full width horse is fitted to the aft beam whilst a curved track is used for the kicking strap.

On hauling the boat ashore, the transom bung is removed and all the water is run out.

The materials list for *UNICORN* is short and the boat's performance does not depend on a number of expensive fittings. After buying his spars and sail and having built his boat from scratch, a home builder can be on the water for as little as £150. To date six

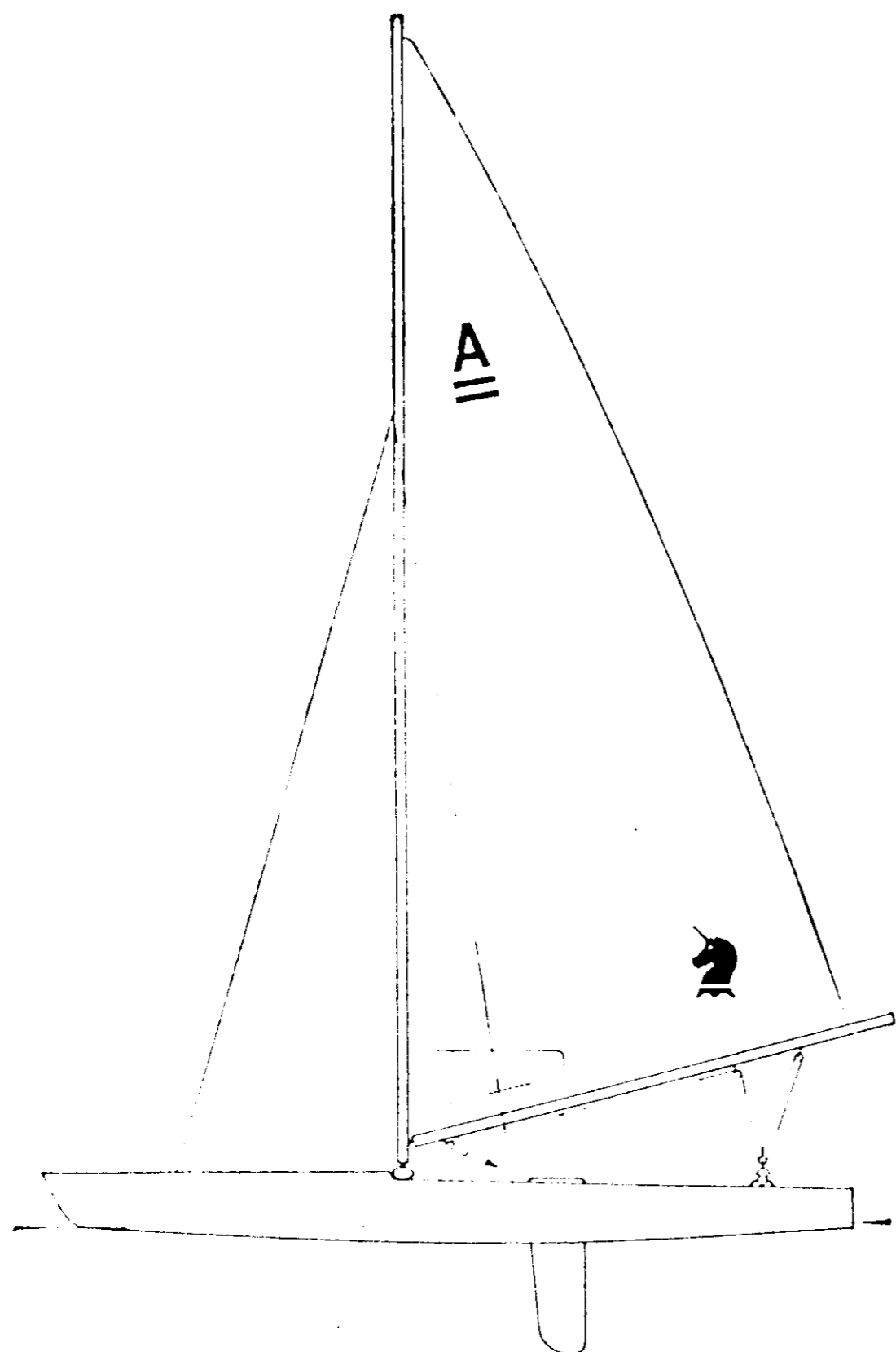

A una rig of 150 sq. ft. is set on a rotating mast supported by one pair of shrouds and a divided forestay.

boats are racing in the class—four of these are home built—and the £150 figure has proved to be a very reasonable average cost.

At the moment *UNICORN* hulls are of all plywood construction, but work is in hand for a fibreglass hulled prototype. This should be an interesting experiment, for the intention is to build a *UNICORN* with one plywood and one fibreglass hull. The boat will then be tested to see which is the first to fail.

UNICORNS are built professionally by Trowbridge and Sons of Durnchurch, Winchester and the cost for a boat complete with sail is £300. Kits are available, of course, and either a complete basic set of

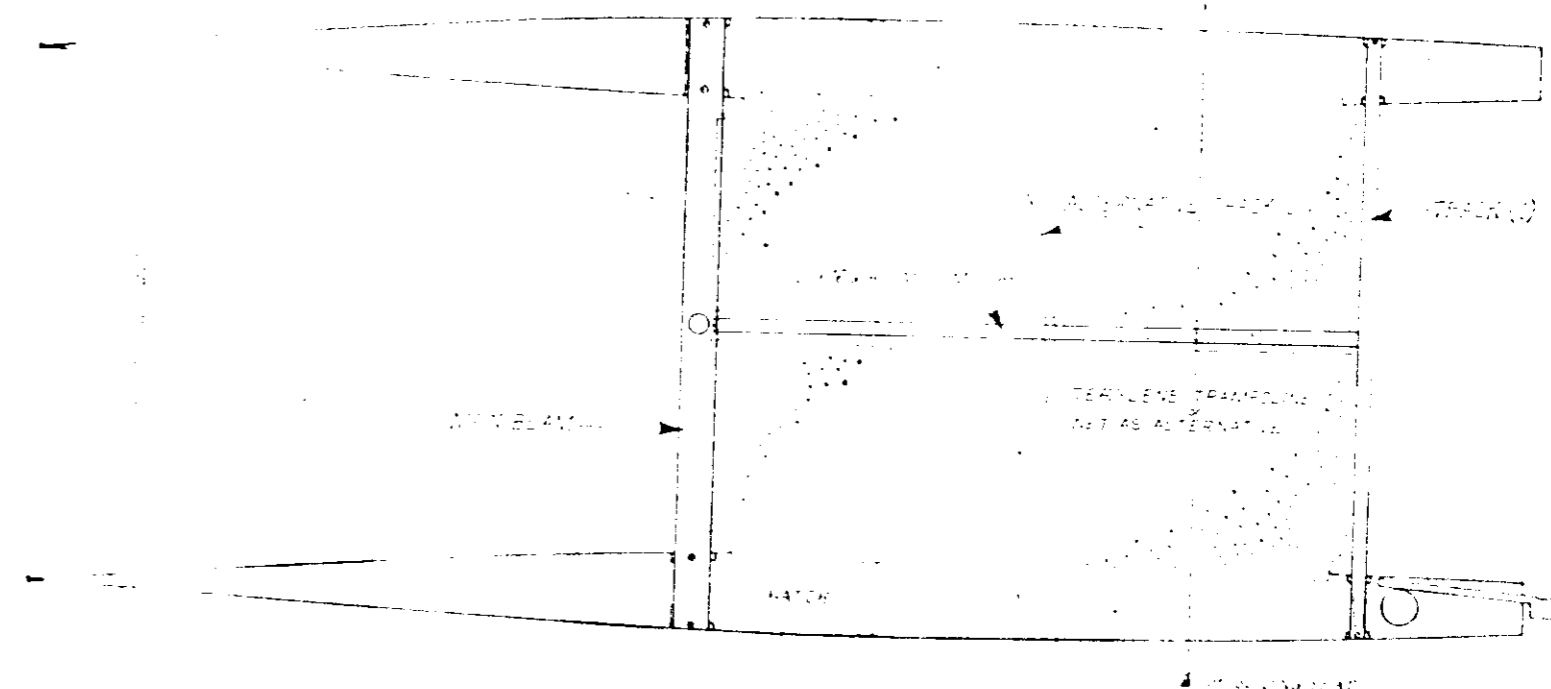

UNICORN's hulls are held apart by two beams, the centre area being filled with a Terylene trampoline supported down the middle by an aluminium tube. Access to the bolts which secure the beams to the hulls is obtained through inspection hatches in the deck.

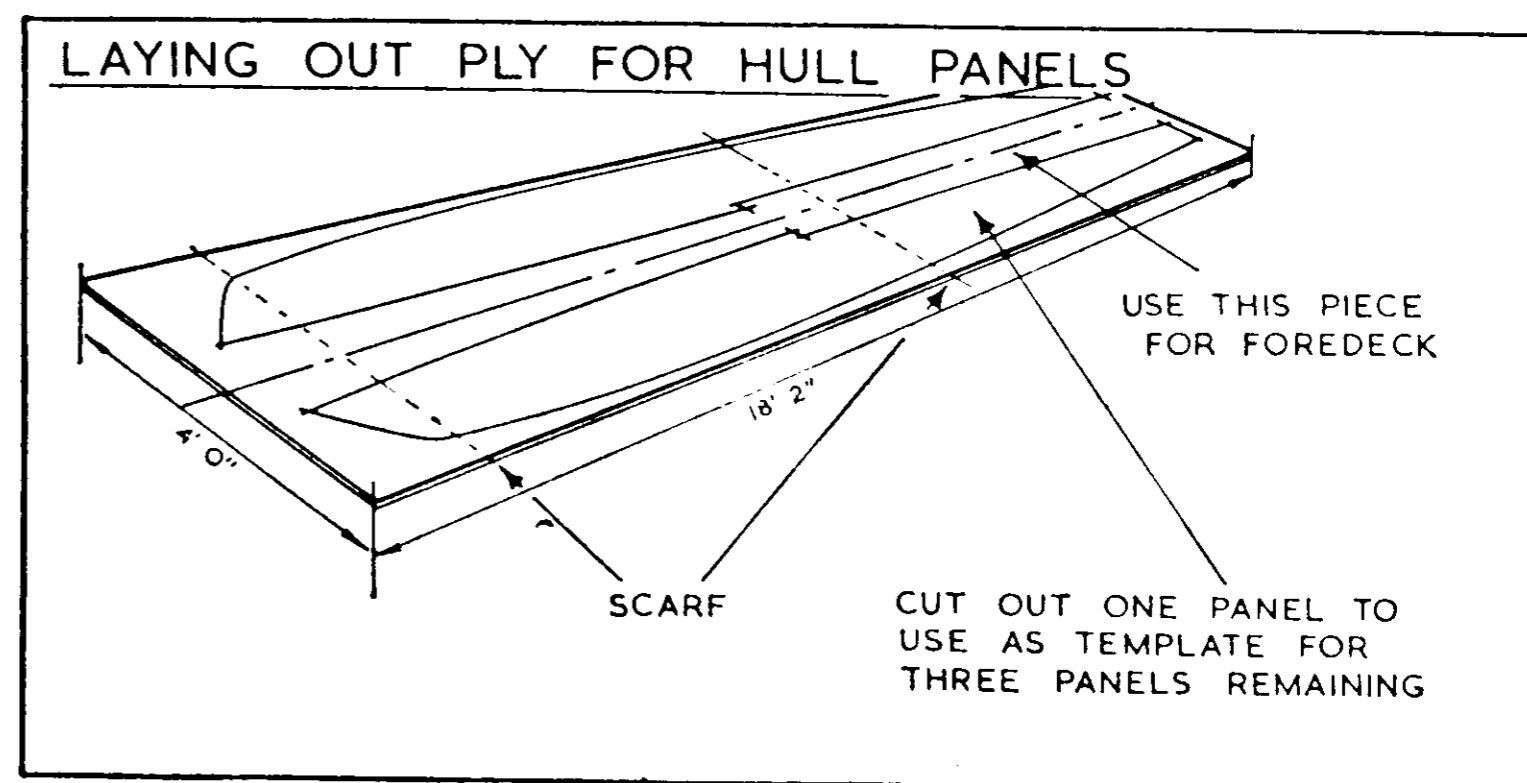

parts can be supplied or the boat can be ordered in any stage of completion. For the cat sailor who is good with his hands and wants to start from scratch, a complete set of working drawings and building instructions can be purchased from the designer for £8 0s. 0d.

CONSTRUCTION

The first job is to scarf together plywood sheets to form two panels 18 ft. 2 in. long x 4 ft. wide. One panel is sufficient for each hull. The width of the scarf should be eight times that of the thickness of the plywood, in this case 32 mm. or about 1 3/8 in. Pressure can be applied to the scarf while gluing by nailing through a strip of packing, through the panel being scarfed and into a wood backing batten.

When the glue has set, the nailed strip can be removed and the holes stopped up when painting. The sketch on the right shows the method of "stitching" the panels together with copper wire prior to fibreglassing the keel joint.

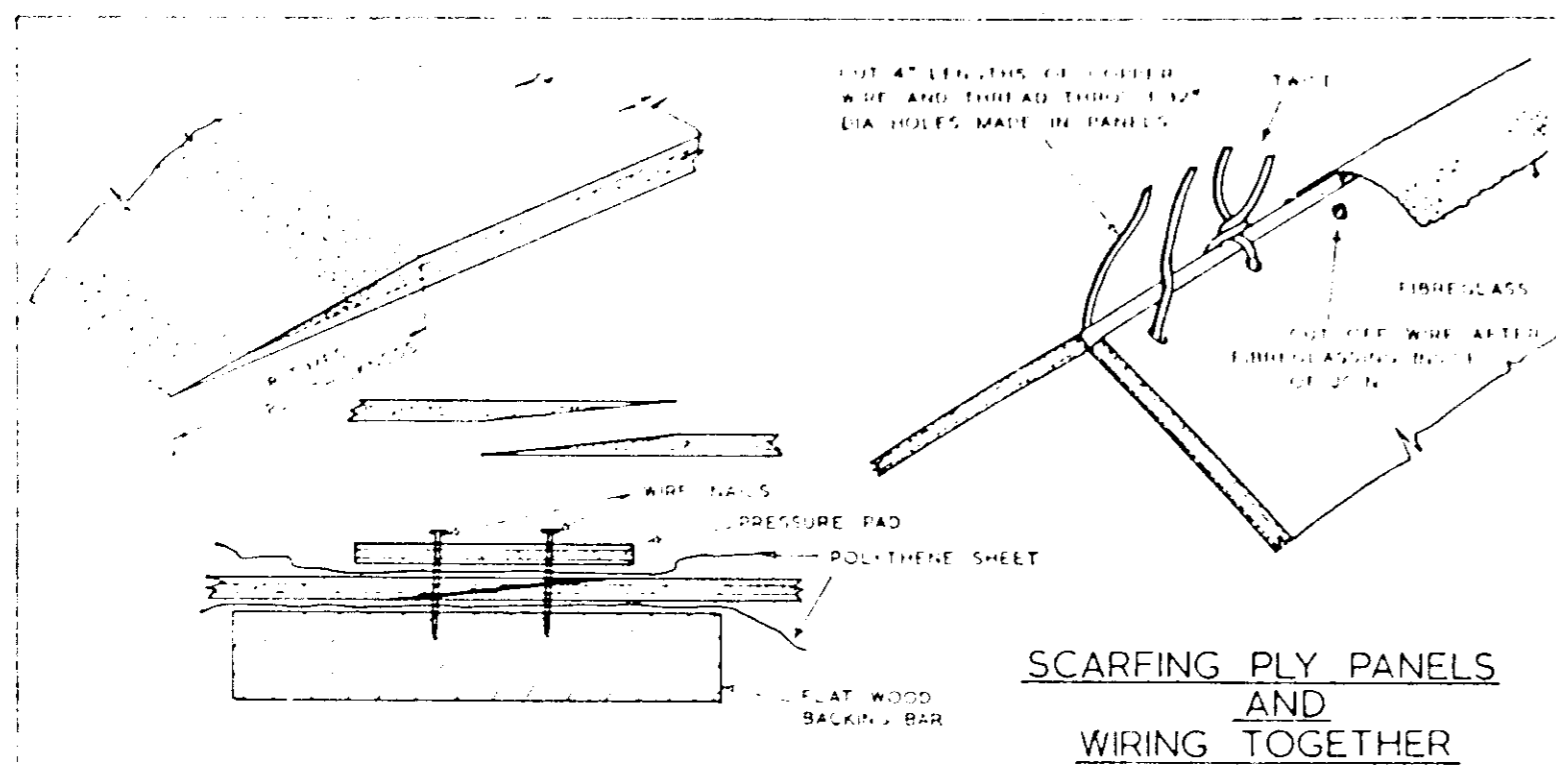

(1) Marking out

A datum line is marked on one panel and the offsets for the keel and deck line are marked off and the outline of the finished panel drawn in. One panel is cut out and carefully finished to shape. This is used as a template to mark out the other panels. Care must be taken to ensure that the face veneer of the plywood appears on the outside of the panel and that the scarf is trailing. That is with the join starting on the inside of the finished panel, forward and running to the outer face of the panel aft. A 10½ in. wide offset of plywood between the hull panels aft is used for the foredeck.

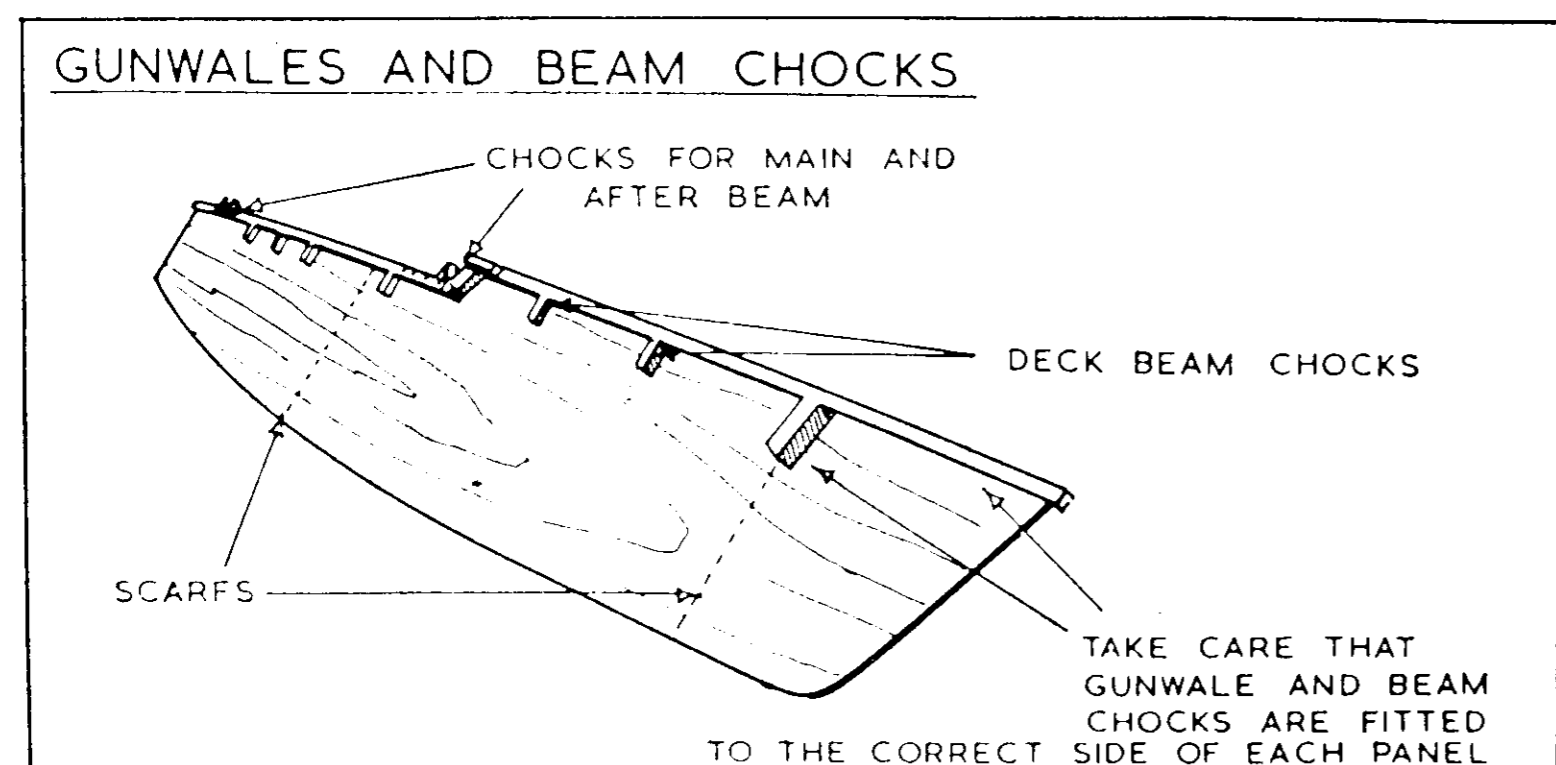

(2) Hull Sides

After the hull sides are cleaned up to shape the gunwhale assembly can be fitted. The ¾ in. square spruce gunwhales are fixed to the upper edge of each panel on the inner face and fastened with glue and barbed ring nails. It is important to make sure that two pairs of right sides and two pairs of left sides are assembled. When the glue has set, each sheet should be marked and cut out where the main beam and rear beam mounting blocks are to be fitted. The blocks and their doubling pieces are then fastened into place. Next, the deck beam chocks are fitted. These are nailed and glued to the panel just below the gunwhale.

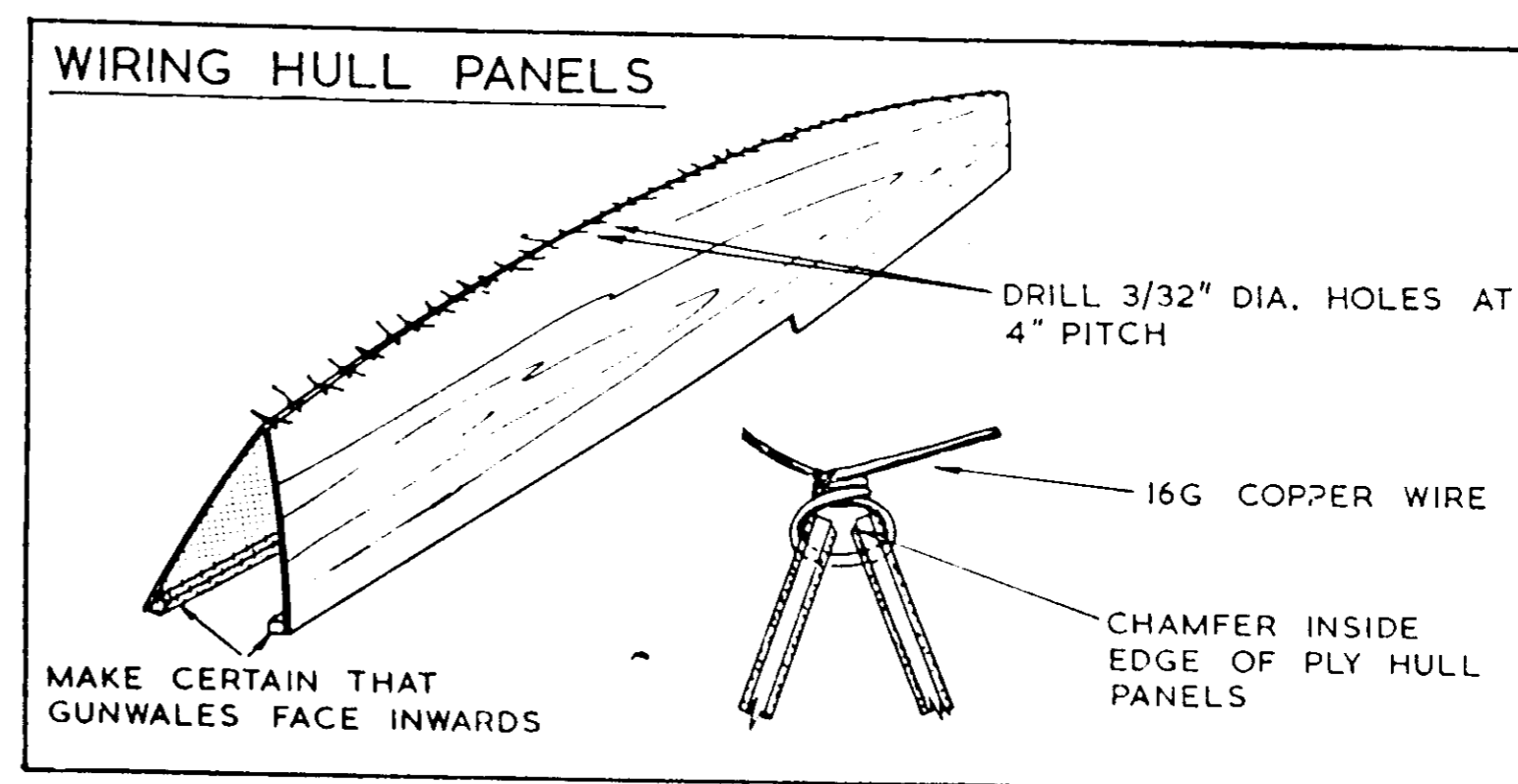

(3) Wiring together

When the glue holding the gunwhales and chocks has set, the gunwhales must be tapered for the forward 10 in. off to nothing at the bow. As this will expose the ends of a number of the fastenings, these will have to be punched back and removed to avoid blunting the plane or chisel. The sides are then paired off and marked so that they cannot be mixed later. Each pair is placed back to back and a row of holes, 3/32 in. in diameter, is drilled along the keel and up the stem. The holes should be about 3/16 in. from the edge of the plywood and spaced at about 4 in. centres. The sides are then reversed so that the gunwhales are inwards and wired together using 3 in. lengths of 16 g. copper wire.

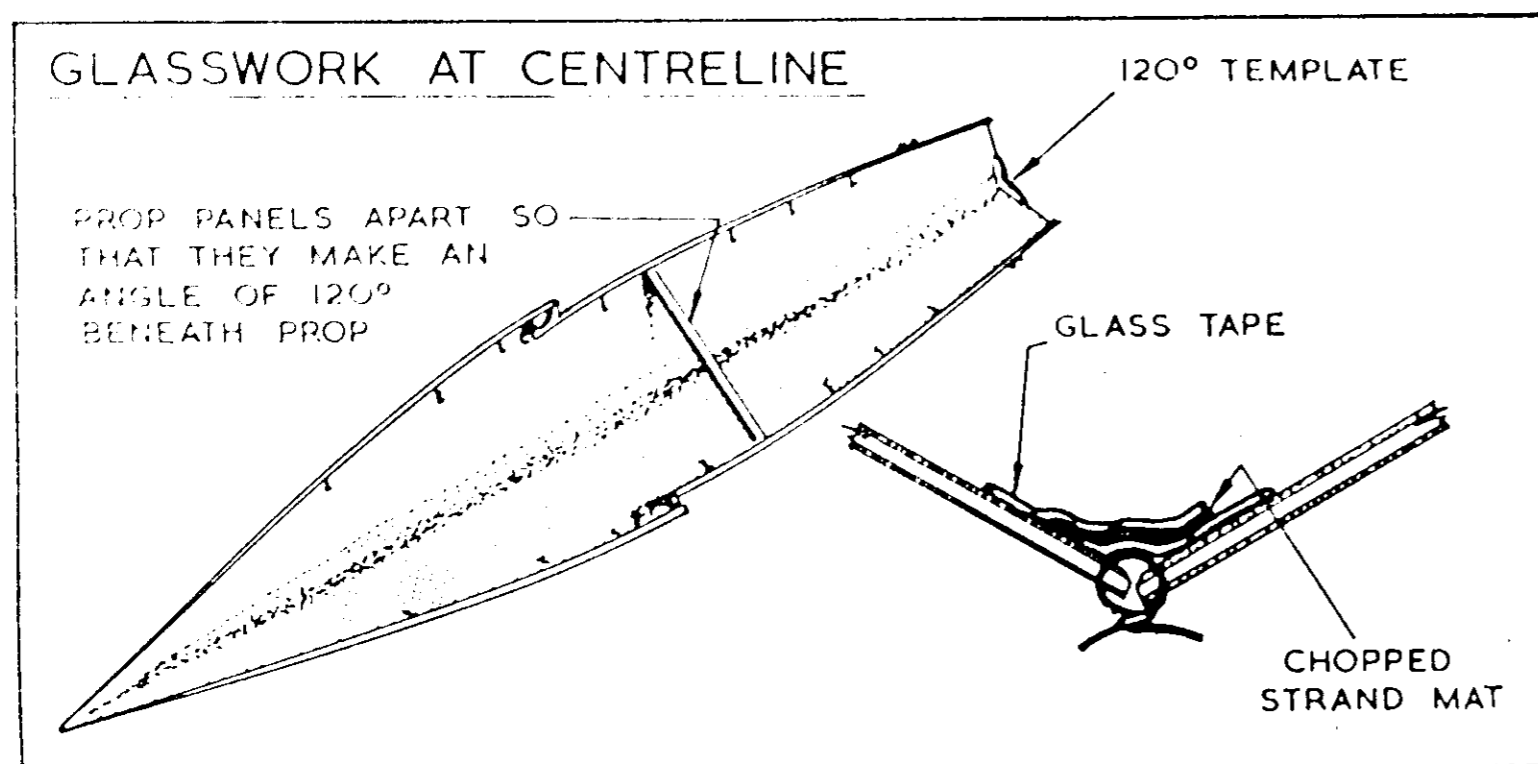

(4) Glasswork at Keel

When the sides have been wired together they are spread apart like opening a book to an angle of about 120° and held in place by a single shore fitted between the gunwales about 2 ft. aft of the main beam position. A template of plywood is cut to 120° and wired to the sides at the stern to maintain the angle right aft. Epoxy resin such as Araldite is recommended for use with the fibreglass for bonding the keel. A strip of 2 in. wide fibreglass tape is bonded to the joint offset ½ in. one way, followed by a 1½ in. wide strip of chopped strand mat down the middle and finally another strip of tape offset the other way. Two, 1 lb. mixes of resin should be sufficient for each hull.

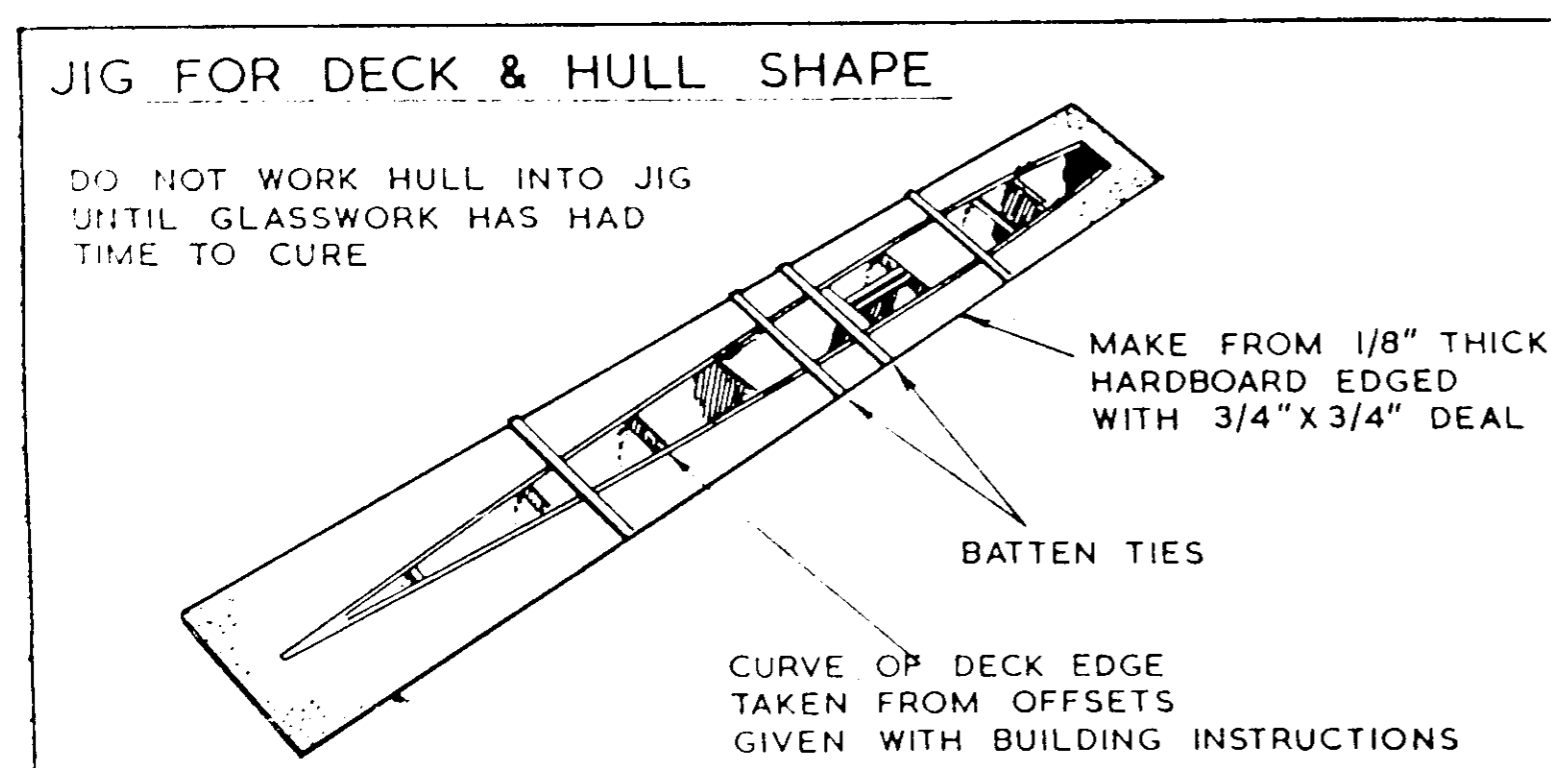

(5) Deck Jig

Once the inside of the hull has been bonded along the keel and the epoxy resin has set the hull is turned over and the wire stitches are clipped off close to the surface of the panels and filed flush. The

sharp corner where the panels meet is rounded over with a plane and two layers of glass tape are bonded over the outside of the join. When the resin has set hard the panels are ready for pulling to shape by fitting them into a jig specially made to dimensions shown on the drawings, or by driving a series of nails into the gunwales and pulling the sides together with line. The bulkheads, centreboard cases and deck beams can now be fitted.

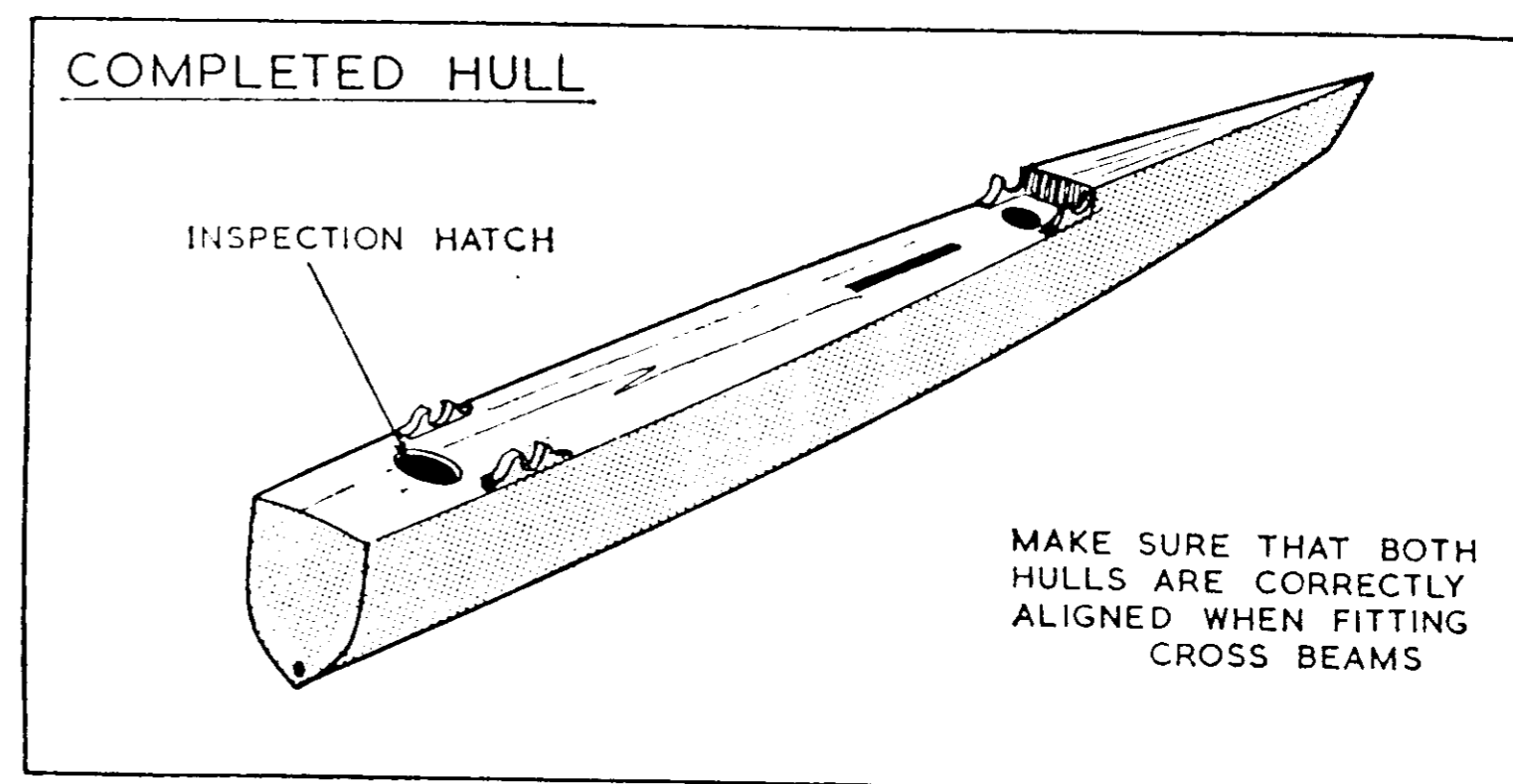

(6) Completing Hull

Once the deck framework and bulkheads are in place the inside of the hull should be painted out with three coats of polyurethane paint. The decks are then marked and painted before being glued and nailed in place. Holes are cut in the deck just aft of each beam to take an inspection hatch and a ply doubler about ¾ in. wide should be fitted round the opening on the inside to take the fastening screws. ¾ in. x ½ in. rubbing strips are fitted to the deck either side of each hull to take the chafe from the sliding seat and the hulls are ready for final sanding and painting. Finally, the hulls must be lined up carefully to eliminate twist and the cross beams fitted.

AUSTRALIS AND TORNADO NOW INTERNATIONAL CLASSES.

I.Y.R.U. CATAMARANS TRIALS AT SHEPPEY, 1967

It may be placed on record here that the R.Y.A., as an organisation, has never been anti-multihull but has followed the development of the racing multihull with interest and quite early set up a "Catamaran Committee". The I.Y.R.U. has followed and last year decided

to select both an "A" Class and "B" Class catamaran for International status through a series of races at the Catamaran Yacht Club, Sheppey. *AUSTRALIS* and *TORNADO* were selected.

"A" CLASS RESULTS

Name	Designer	Helmsman	Points
<i>Australis</i> (Australia)	Johnston	G. E. Johnston	20.7
<i>Bambi</i> (U.K.)	Prout Coster	N. T. Coster	25.4
<i>Catalina</i> (Denmark)	Smitt	L. Wagner-Smitt	34.0
<i>Unicorn</i> (U.K.)	Mazzotti	J. Mazzotti	35.1
<i>Sail Fast</i> (U.K.)	Hubbard	R. J. Osborn	49.4
<i>Miss Rothmans</i> (N.Z.)	Stanton Cooke Bros.	G. B. Stanton	49.7
<i>Lo-Ka</i> (U.S.A.)	Karcher	R. F. Lostrom	68.4
<i>Iolanthe II</i> (U.K.)	Butcher	P. Butcher	78.7

AUSTRALIS won 3 races while *BAMBI*, *CATALINA*, *UNICORN* and *SAIL FAST* won a race each, so the boats can be said to be fairly evenly matched. *MISS ROTHMANS* dug her fore beam in waves and threw spray. *LO-KA* was fibreglass and therefore probably heavy.

Design-wise, the boats were very similar in shape. All had fine bows which experience shows go through waves without stopping so much. *AUSTRALIS*, however, had a sharp stern which did not seem to slow her at all. "A" Class cats pitch much more than larger catamarans and this fine stern might, under these circumstances, have more than made up for the extra (strong wind) resistance, while the lesser wetted surface helped in light winds.

"B" CLASS RESULTS

Boat	Designer	Helmsman	Points
<i>Tornado I</i> (U.K.)	Rodney March	R. White	8.7
<i>Mehitabel</i> (Australia)	Cunningham Blaxland	P. Blaxland	25.7
<i>Thai-Foon</i> (U.K.)	MacAlpine-Downie	K. L. Sanger	69.1
<i>Vivace</i> (U.K.)	Mazzotti	A. G. J. Smith	70.7
<i>Yankee B (B-Lion)</i> U.S.A.	Hubbard	Mark Smith	76.7
<i>Roton Pointer</i> (U.S.A.)	G. W. Patterson	J. Bonney	82.4
<i>Ready Steady Gone</i> (U.K.)	Prout	R. G. Prout	83.1
<i>Pacific Cat</i> (U.S.A.)	Newport Boats	R. Baker	85.7

Boat	Designer	Helmsman	Points
<i>Tornado II</i> (U.K.)	Rodney March	T. K. Pearce	91.0
<i>Centennial</i> (Canada)	Perry/Carter	G. S. Percy	104.0
<i>Yellow Bird</i> (U.K.) (<i>Shearwater III</i>)	Prout	F. Prout	113.7

TORNADO and *MEHITABEL* had this series more or less between them. The older, beamier and heavier boats were out-classed. One could guess that the points obtained were almost in proportion to the weights of the boats concerned.

MEHITABEL is a more or less typical Cummingham (*QUEST*) type but sports a small transom about 3 in. in width. She is tremendously light with semicircular sections based upon the L.W.L. throughout, as compared with the sharper sections of the other boats forward.

Postscript. We have most certainly made some progress in catamaran design since 1955 but the *SHEARWATER IV* still acquitted herself well against the latest, longer, larger and leaner boats and, after all, the *TORNADO* is not very different in design from the dear old *SHEARWATER*.

TORNADO

A B Class catamaran for international racing designed by RODNEY MARCH

by courtesy of the Editor, Yachting World

L.O.A. 20.0 ft. Beam 10.0 ft. Sail Area 235 sq. ft.

TORNADO was designed with the requirements of the International Yacht Racing Union for a B Class catamaran well in mind, and to such good purpose that, following the trials at Sheppey in August, she is the boat that will be recommended to the I.Y.R.U. at its November meeting by the Observation Committee as a one-design class suitable for international racing. Rodney March set out to design a boat which would have an exceptional performance. This characteristic would necessarily stem partly from a light boat which in turn would make her easy to handle ashore. The third important factor is that *TORNADO* is especially suitable for amateur construction, using the "bent ply" method of forming the hulls.

TORNADO's construction is the same as the bent ply method employed for *THUNDER II*, which was a development of John Mazzotti's *MANTA* construction. By pre-setting the keel angle



Successful prototype TORNADO, international catamaran of the future.

when initially sewing and taping the keel together it is easily possible to maintain accurately a definite hull shape which can be repeated exactly. Three bulkheads and a piece of pre-shaped polystyrene foam for the forward stations assure perfect conformity to hull lines.

This method of construction lends itself well for amateur construction as only the minimum of jiggling is required to hold the two 4.5 mm. ply halves of each hull at the correct angle while the epoxy bonded glass tape sets. A further simple jig is made to give the correct deck level plan. This jig can simply be made from hardboard with a piece of $\frac{7}{8}$ in. square screwed around the hole pre-cut to accept the hull.

The result is a hull with very soft lines which, in spite of the thin skin, is strong, rigid and very light.

The now familiar configuration of aluminium beams and Terylene "trampoline" are used to tie the two hulls together and plug the hole between hulls. Four stainless steel straps on each hull hold down the beams which correctly align the hulls on assembly. The bolt ropes of the trampoline fit into aluminium extrusions screwed to the hulls

and into the after beam, which is a mast section complete with full groove.

TORNADO promises to be a very popular boat; she is undoubtedly very exciting and for the first time brings in the added requirement of downwind tacking even in lighter winds, hitherto a waste of time with boats of her size except in special conditions.

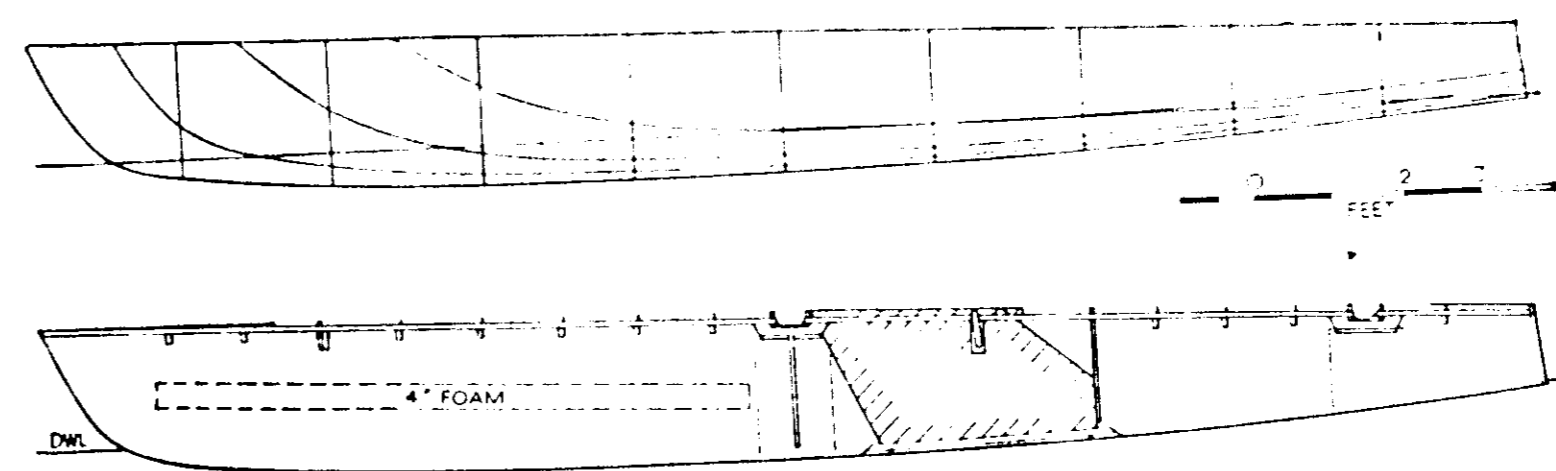
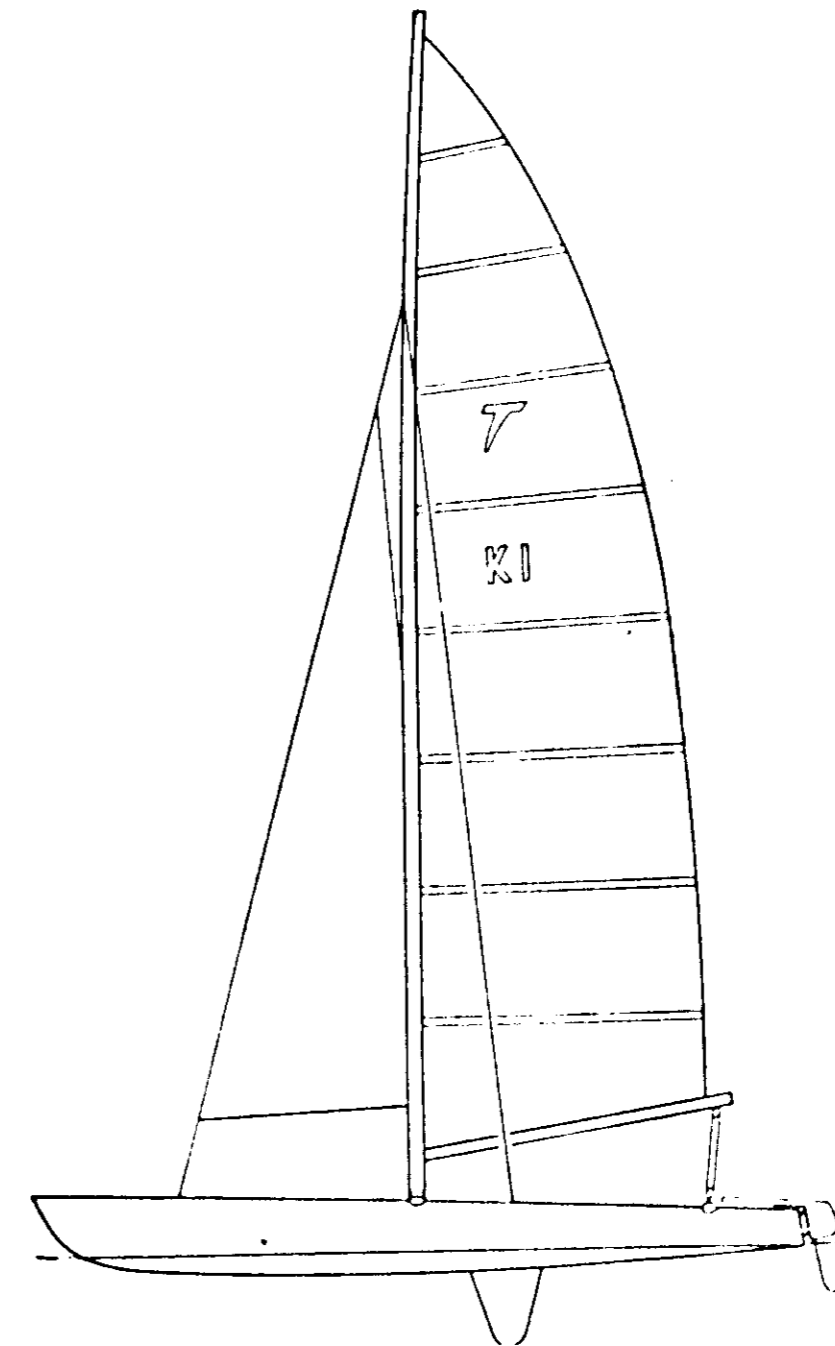

*Production boats from Sailcraft, Brightlingsea, Essex, cost £495, ex sails.
Kit £338 including sails.*



Successful prototype *TORNADO*, international catamaran of the future.

when initially sewing and taping the keel together it is easily possible to maintain accurately a definite hull shape which can be repeated exactly. Three bulkheads and a piece of pre-shaped polystyrene foam for the forward stations assure perfect conformity to hull lines.

This method of construction lends itself well for amateur construction as only the minimum of jiggling is required to hold the two 4.5 mm. ply halves of each hull at the correct angle while the epoxy bonded glass tape sets. A further simple jig is made to give the correct deck level plan. This jig can simply be made from hardboard with a piece of $\frac{7}{8}$ in. square screwed around the hole pre-cut to accept the hull.

The result is a hull with very soft lines which, in spite of the thin skin, is strong, rigid and very light.

The now familiar configuration of aluminium beams and Terylene "trampoline" are used to tie the two hulls together and plug the hole between hulls. Four stainless steel straps on each hull hold down the beams which correctly align the hulls on assembly. The bolt ropes of the trampoline fit into aluminium extrusions screwed to the hulls

and into the after beam, which is a mast section complete with luff groove.

TORNADO promises to be a very popular boat; she is undoubtedly very exciting and for the first time brings in the added requirement of downwind tacking even in lighter winds, hitherto a waste of time with boats of her size except in special conditions.

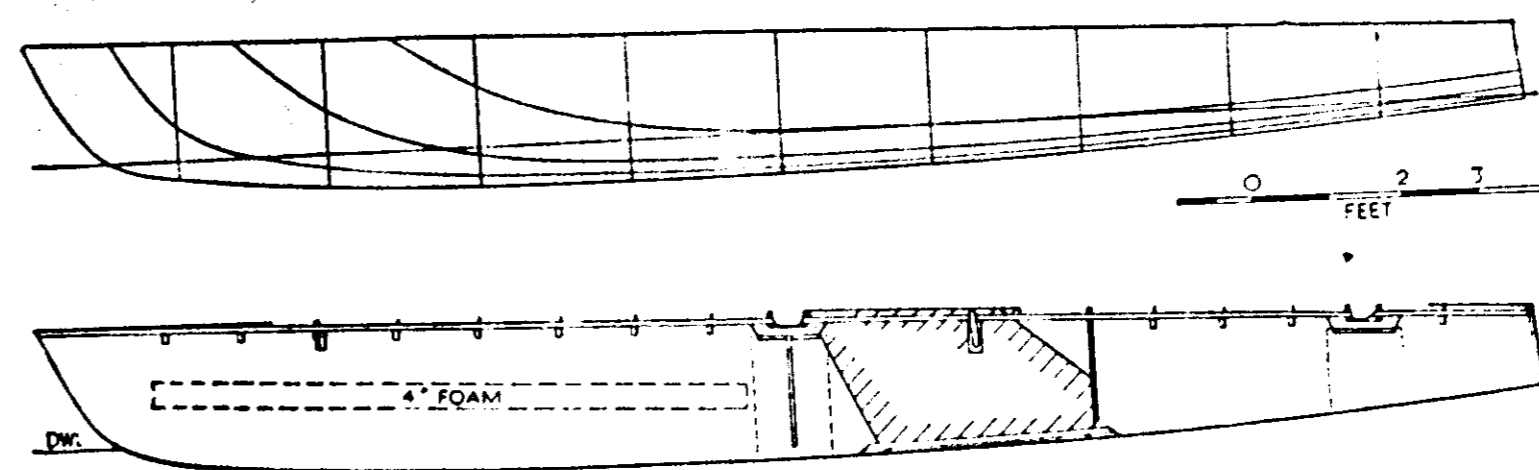
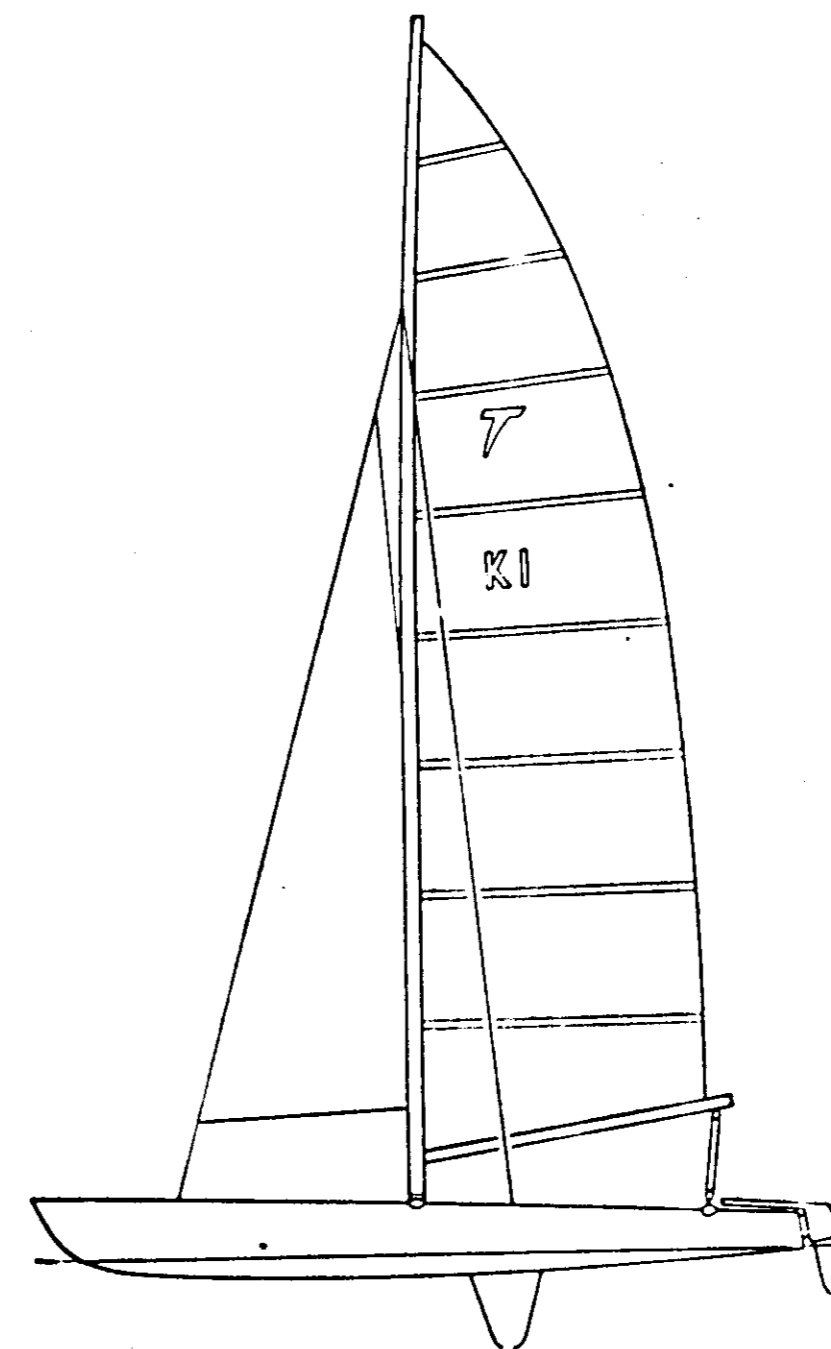

Production boats from Sailcraft, Brightlingsea, Essex, cost £495, ex sails.
Kit £338 including sails.