

NOTES: UNLESS OTHERWISE SPECIFIED.

1. FOR DIMENSIONS NOT SHOWN SEE COMPUTER GENERATED FILE: MW-1003 REV: 2
 2. MATERIAL: AL 6061
 3. FINISH: TBD
 4. FINISH: TBD
 5. FINISH: TBD
 6. PLATING: TBD
 7. PAINT: NONE
 8. ONE HALF OF A FEATURE DIMENSIONED ACROSS A CENTER LINE AND/OR A SYMETRIC CALLOUT IS EQUAL TO THE DIMENSION SHOWN DIVIDED BY TWO AND ITS TOLERANCE DIVIDED BY TWO.
 9. BREAK AND DEBURR ALL SHARP EDGES.
 10. PART TO BE FREE FROM DIRT AND OILS.
11. MARK ITEM WITH PART NUMBER AND LATEST REVISION LEVEL IN 0.125-0.250 HIGH CHARACTERS APPROXIMATELY WHERE SHOWN. USE PERMANENT INK OF CONTRASTING COLOR.

REVISIONS				
ZONE	REV	DESCRIPTION	DATE	APPROVED
--	1	INITIAL RELEASE	02014-SEP-24	--
--	2	MOUNTING HOLES	02014-SEP-25	--

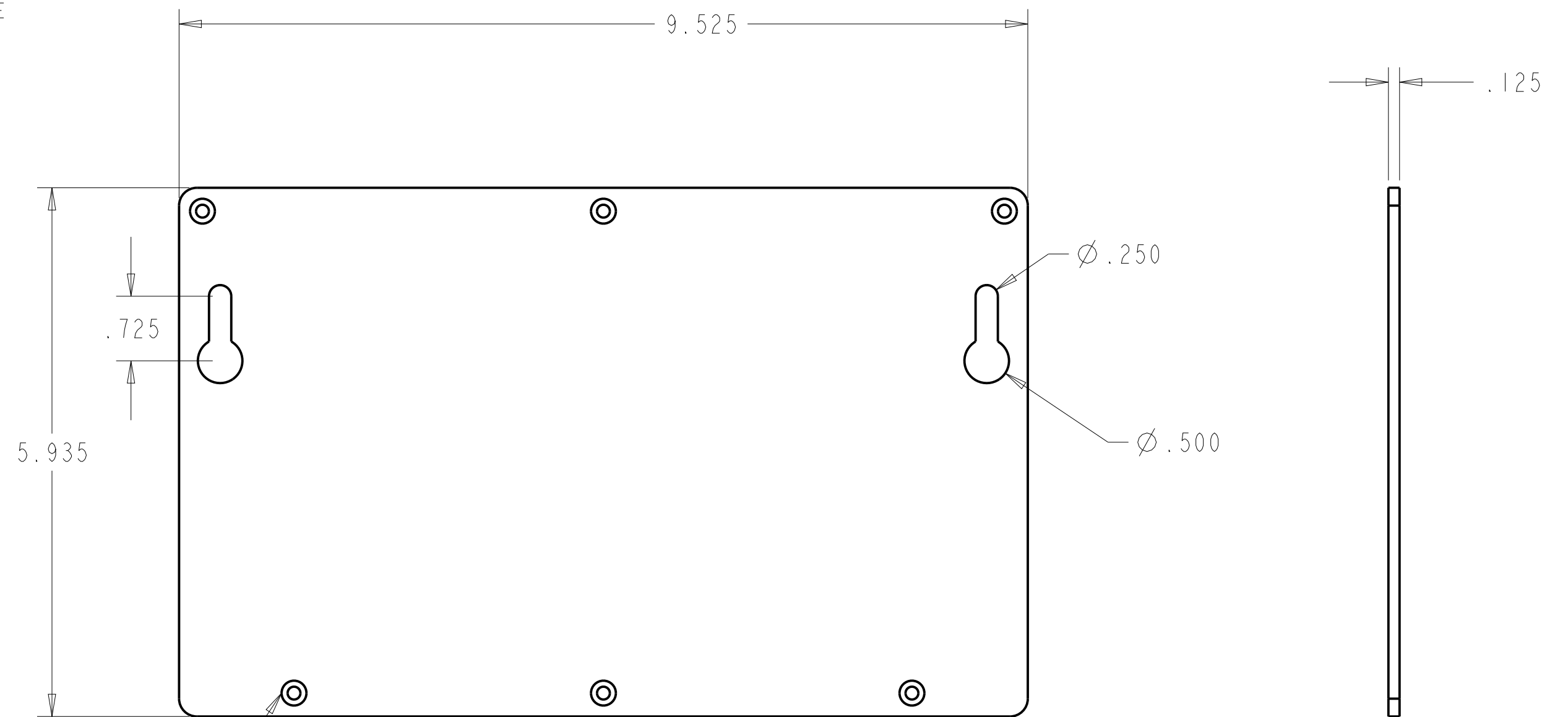

6-32 UNC - 2B CLEAR
#27 DRILL (0.144) THRU -(1) HOLE
6X

UNLESS OTHERWISE SPECIFIED DIMENSIONS ARE IN INCHES.	PRO/E REPORTED PARAMETERS		DESIGNER	
	TOLERANCES ARE:	PRO/E MATERIAL	P SALVAGIONE	
.X +/- 0.1	AL6061	ENGINEER	P SALVAGIONE 02014-SEP-24	
.XX +/- 0.01	PRO/E MASS	DRAFTER	P SALVAGIONE 02014-SEP-24	
.XXX +/- 0.005	0.681	CHECKED	---	
ANGLES +/- 0.5	PRO/E VOLUME		02014-MMM-DD	
	6.955			
INTERPRET DIMENSIONS PER ASME Y14.5M 1994 (R2004)	PRO/E DRAWING FILE NAME:	DO NOT SCALE DRAWING		
	MW-1003			

SALVAGIONE DESIGN		
ALUMINUM BACK PLATE		
SIZE	CUSTOMER DRAWING/PART NO.	REV
C	---	2
	DRAWING/PART NO.	
	MW-1003	
SCALE	0.750	SHEET 1 OF 2

CUSTOMER DRAWING/PART NO. ---
DRAWING/PART NO. MW-1003
REV 2
SHT 1

